

PAGE[®]

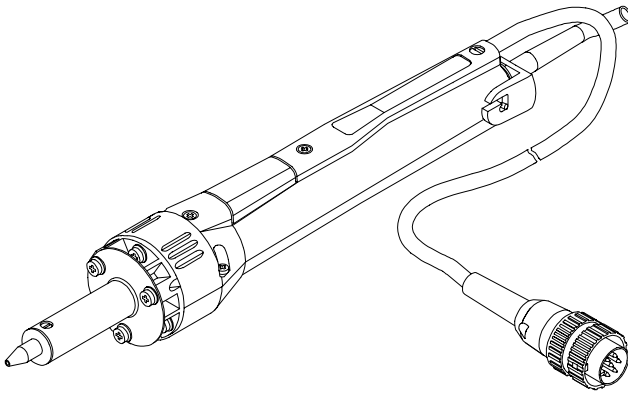

SX-70



SX-70 Sodr-X-Tractor Handpiece

Operation & Maintenance Instructions

SX-70

PACE Incorporated retains the right to make changes to specifications contained herein at any time, without notice.

Contact your local authorized PACE Distributor or PACE Incorporated to obtain the latest specifications.

The following are registered trademarks and/or servicemarks of PACE Incorporated, Laurel Maryland U.S.A. and may only be used to identify genuine PACE products or services:

Arm-Evac, Cir-Kit, ConducTweez, CRAFT, Flo-D-Sodr, Heat Wave, HotSpot, LapFlo, MBT, Micro Portable, MicroChine, MiniChine, Mini-Wave, PACE, Pacenter, Pik-Tip, PETS, Prep-Set, ResisTweez, SensaTemp, Snap-Vac, Sodr-Pen, Sodr-X-Tractor, ST, StripTweez, Thermo-Drive, ThermoFlo, ThermoJet, ThermoPart, ThermoPik, ThermoTweez.

The following are trademarks and/or servicemarks of PACE Incorporated, Laurel Maryland U.S.A. and may only be used to identify genuine PACE products or services:

Sodrtek, Toolnet.



Since 1958, PACE Incorporated has provided advanced technology training in all aspects of hand soldering, rework and repair.

For any questions regarding this Operation & Maintenance Manual, contact your local authorized PACE distributor or contact PACE directly at the appropriate address listed below.

PACE Inc. 9893 Brewers Court, Laurel, Maryland 20723-1990
Tel. (888) 535-7223 (toll-free), (301) 490-9860
FAX 301 483 7030

PACE Europe Ltd. Sherbourne House Sherbourne Drive Tilbrook
Milton Keynes Buckinghamshire England MK7 8HX
Tel. (44) 01908 277 666 FAX (44) 01908 277 777

© 1999 PACE Incorporated, Laurel MD. All rights reserved. Printed in the U.S.A.

**SX-70
Sodr-X-Tractor Handpiece
Part Number 6010-0100
Manual Number 5050-0334
Rev. E**

SX-70

These instructions detail the basic operational guidelines for using the SX-70 Sodr-X-Tractor handpiece.

Introduction

The SX-70 Sodr-X-Tractor handpiece provides thermally enhanced through-hole desoldering on extra heavy multilayer assemblies, at safer, lower temperatures, even during continuous use and features a large easy-to-clean solder reservoir. The SX-70 also provides safe removal of TQFP (Thin Quad FlatPack) and TSOP (Thin Small Outline Package) surface mount components and continuous removal of old solder from surface mount lands. Its slim-line, pencil grip design and finger actuated vacuum switch facilitates ease of use and manipulation in tight places. The SX-70 is a member of the PACE SensaTemp family of advanced handpieces.

CAUTION

Always return heated handpieces to the appropriate Tip & Tool Stand when not in use. Failure to do so may cause burns to the operator, equipment or work surfaces and may be a potential ignition source if combustible materials are nearby. Always use this handpiece in a well ventilated area to avoid inhalation of fumes created by solder flux.

NOTES

When using your SX-70 Sodr-X-Tractor handpiece for the first time or if you have just replaced the heater, we recommend that you follow the "SX-70 Heater Burn-in" procedure (Red tag on handpiece) to increase the life expectancy of the heater.

Always use your SX-70 Sodr-X-Tractor with a clean VisiFilter element. Otherwise a deterioration in performance or damage to the unit may occur.

Select and enter your desired true operating temperature on your PACE power source. To save tip life and reduce the possibility of damage, PACE recommends using the lowest possible tip temperature that will provide rapid yet controllable melt of the entire solder joint to be extracted. Begin with an operating temperature in the range of 316°C (600°F) and adjust as necessary.

Tip & Tool Stand Setup

If you have purchased a SX-70 handpiece with a Tip & Tool Stand, set up the Tip & Tool Stand in the following manner.

1. Place 4 Rubber Feet on the bottom corners of the enclosed Tip & Tool Stand.

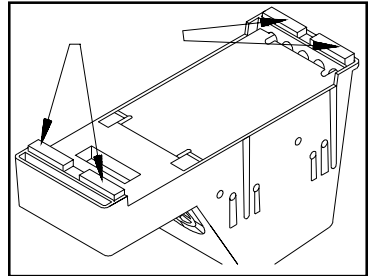

2. The SX Tip & Tool Stand can be attached to some PACE power sources. Refer to the power source Operation & Maintenance manual for the applicable instructions.

3. Place the sponge in the Tip & Tool Stand using the following procedure.
 - a) Remove the 2 small punched out center portions of the sponge & place into the sponge well of the stand in the position shown.
 - b) Place the large sponge section into the sponge well as shown.
 - c) Dampen the sponges with water.

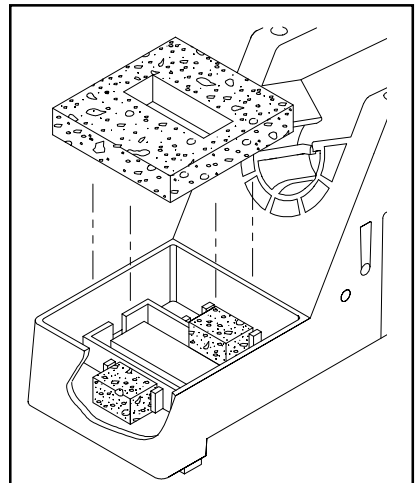

4. Place the handpiece into its Tip & Tool Stand.

SX-70

Handpiece Setup

NOTE

If using your SX-70 handpiece for the first time or if you have just replaced the heater, we recommend that you follow the “SX-70 Heater Burn-in” procedure (Red tag on handpiece) to increase the life expectancy of the heater.

Handpiece Connection

Connect the handpiece connector plug into one of the Power Receptacles on your PACE power source in the following manner.

1. Align guide on connector with slot on power receptacle.
2. Insert connector into power receptacle.
3. Turn the connector housing clockwise to lock in place.

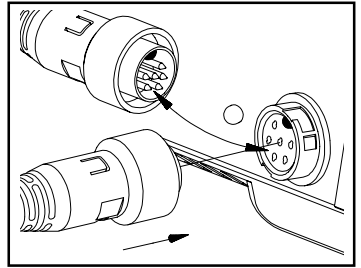

Air Hose Connection

NOTE

Ensure that only one air handpiece is connected to either the **Vacuum Port** or Controllable **PRESSURE Port** at one time. Attachment to both ports simultaneously will cause a deterioration of performance.

To set up your SX-70 air hose connection, perform the following steps:

1. Air Hose To Handpiece Connection
 - a) Attach one end of a 137cm (54 inch) length of air hose to the metal tube in the back of the handpiece.
 - b) If you have a PACE system incorporating only one handpiece, attach the air hose to the SX-70 power cable using the supplied Hose Clamps. Space them evenly along the length of the power cable starting at a point 6 inches from the ends of the handpiece.
 - c) If you have a PACE system incorporating 2 or more air handpieces (e.g., SX-70, DTP-80, TJ-70, TP-65), you may wish to leave the air hose assembly unattached to allow a quick change to any air handpiece being used.

2. Prepare a VisiFilter in the following manner:

- a) Connect a 1 inch (2.5cm) length of clear pvc air hose to the FLOW OUT side of the VisiFilter; push and turn the hose onto the VisiFilter nipple to seat.
- b) Insert the ribbed end of a male quick connect hose mount fitting (P/N 1259-0087) into the free end of the 1 inch (2.5cm) length of air hose connected to the FLOW OUT side of the VisiFilter.
- c) Connect the free end of the 137cm (54 inch) length of air hose to the FLOW IN side of the VisiFilter.
- d) Insert the end of the quick connect hose mount fitting (on VisiFilter FLOW OUT side) into the power source Vacuum Port.

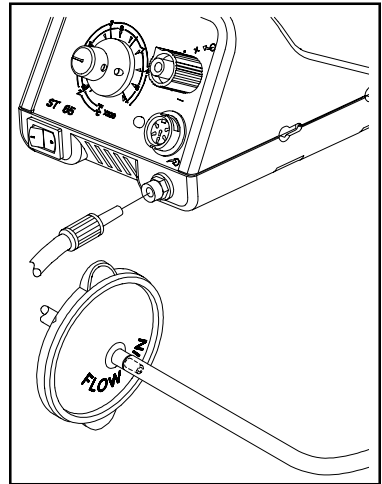

3. When using air pressure, and/or utilizing multiple air handpieces, PACE recommends the use of the following set up procedure which utilizes additional quick connect hose mount fittings. An assortment of quick connect air fittings are supplied with each additional air handpiece.

- a) Disconnect the 137cm (54 inch) length of air hose from the FLOW IN side of the VisiFilter assembly. Insert the ribbed end of a male quick connect hose mount fitting (P/N 1259-0087) into the free end of this air hose.
- b) Connect the free end of a 1 inch (2.5cm) length of air hose with an installed female quick connect hose mount fitting (P/N 1259-0086) to the FLOW IN side of the VisiFilter Assembly.
- c) The 137cm (54 inch) length of air hose can now be easily moved between the VisiFilter Assembly and the Controllable Pressure Port. The VisiFilter assembly remains connected to the Vacuum Port.

4. Additional fittings may also be added to the hose connection at the rear of each air handpiece to ease changing of handpieces.

NOTE

When removing any air hose, turn and pull. Do not attempt to pull hose directly off. Damage to or breakage of fitting or VisiFilter may occur. Use your SX-70 Sodr-X-Tractor with a clean VisiFilter element. Otherwise a deterioration in performance or damage to the unit may occur.

SX-70

Tip Selection

PACE Sodr-X-Tractor Tips come in three basic types.

1. **Desoldering Tips** - These tips are tinnable and provide enhanced thermal performance for thru-hole desoldering on high mass boards.
2. **Pik-Tips** - Provide safe removal of TQFP (Thin Quad FlatPack) and TSOP (Thin Small Outline Package) surface mount components.
3. **Flo-D-Sodr Tips** - These tips provide rapid, continuous extraction of old or excess solder from SMT lands.

Size selection of tips is important. For thru-hole desoldering, select a tip with an I.D. just large enough to allow the lead to freely pass inside. The tip O.D. should not exceed the diameter of the land to minimize risk of damage to the board substrate. When removing TQFPs or TSOPs, the Pik-Tip should be sized so that the tip blades make proper contact with all the lead/land connections simultaneously.

Tip Installation

For maximum productivity and proper fit, install tips into your SX-70 Sodr-X-Tractor when the heater is hot.

CAUTION

Hold the handpiece with the heater pointed at an angle up to prevent injury to personnel.

1. Insert the Tip fully into heater bore using supplied Tip Tool.
2. Gently tighten the Heater Set Screw.
3. Recheck the Heater Set Screw periodically to insure that it remains snug.

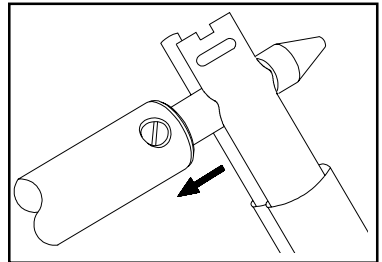

NOTE

Periodically, clean the heater bore with a properly sized wire brush (3/16" O.D. to insure optimum heat transfer and proper tip grounding.

Temperature Setting

To save tip life and reduce the possibility of damage to the PCB, PACE recommends using the lowest possible tip temperature that will provide rapid yet controllable melt of the entire solder joint. Begin with an operating temperature of 316°C (600°F) and adjust as necessary. Tip temperatures in excess of 399°C (750°F) may cause damage. For safest removal, some components on extra heavy assemblies may require preheating or auxiliary heating.

Tip Preparation

Proper tip preparation will insure optimum results and increase tip life. Follow this procedure before each component removal or land preparation operation and prior to storage of the handpiece in its Tip & Tool Stand.

NOTE

The use of a PACE Tip Maintenance Station (PACE part number 6993-0138) is recommended for the proper preparation and maintenance of all SX-70 Pik-Tips. To purchase this item, contact your local authorized PACE dealer.

1. Ensure that the installed tip is at set tip temperature.
2. Using a moistened sponge, remove all solder dross and flux residue from the tip.

NOTE

Ensure that the sponge material is moist and free of debris. Add water if necessary. Wiping the heated tip on a dry sponge will only contaminate the tip and ultimately the board.

3. All 3/16" shank tips are tinnable. Using a large gauge, flux cored wire solder, tin the end of these tips. Proper tinning enhances heat transfer to lands and extends tip life.
4. During Flo desoldering or Thru-hole desoldering, on heavily fluxed or contaminated boards, debris may collect inside the tip bore. If this occurs, clean the tip bore with the Sodr-X-Tractor Tip Cleaning Kit (PACE part number 6993-0200).
5. The SX-70 handpiece is now ready for use. If not immediately using the handpiece, store in its Tip & Tool Stand.

Thru-Hole Solder Extraction

1. Ensure that the air hose is connected to a VisiFilter and the Vacuum Port on the power source. Select an operating temperature that will cause complete solder melt in 2-5 seconds (somewhat longer on heavy multilayer boards). A tip temperature of 316°C (600°F) is recommended for most applications.
2. Position your index finger on the handpiece vacuum control switch.
3. Gently position the extractor tip over the lead contacting the solidified solder keeping tip perpendicular to the pad and board.

NOTE - Do not apply pressure against the pad at any time during this operation. Damage to the board may result.

4. Gently move the lead ...
 - a) in a circular motion for round leads
 - b) in a back and forth motion for flat leadsuntil the lead moves freely. Free lead movement indicates that complete solder melt has been obtained.

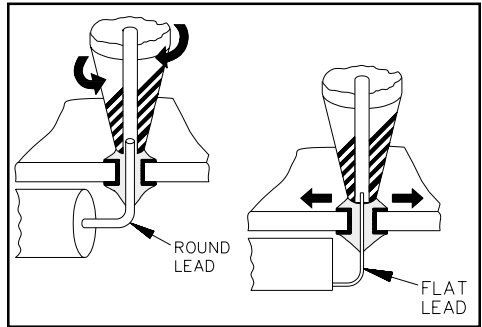

5. While continuing to move lead, actuate vacuum with the finger switch and keep on for at least 2 seconds to cool joint and prevent resweating. The length of time from when heat is applied until the time vacuum is started (i.e., complete solder melt) should be 2-5 seconds under normal conditions. Heavy multilayer boards may require somewhat longer heating times. In extreme cases, preheating or auxiliary heating is recommended to achieve the safest results.

NOTE

Premature actuation of the vacuum may result in incomplete removal of solder from the joint being desoldered. Free movement of the lead is the workpiece indicator that proper solder melt has been achieved. In the event that all the solder has not been removed from the hole, resolder the hole and try again after the board has been allowed to cool.

6. Remove tip from pad and continue vacuum application for an additional 2 seconds to insure that all residual solder is drawn into the solder collection chamber.
7. Retin tip using large gauge flux cored solder and return SX-70 to its Tip & Tool Stand.
8. After all leads are desoldered, the component is easily removed. If any solder should remain in the plated thru-hole after extraction, resolder the connection and perform this procedure again.

Surface Mount Component Removal

TQFP and TSOP surface mount components can be removed using the SX-70 handpiece and the appropriate Pik-Tip. Old or excess solder can be removed from surface mount lands using PACE Flo-D-Sodr tips.

PACE recommends the use of the Manual Assembly and Rework For Surface Mount manual (P/N 6031-2107) as a guide for developing repair/rework procedures for your particular applications.

Tip Cleaning

During heavy, continuous desoldering, on boards with flux residues or other contamination, the tip may occasionally become clogged with such material. If this should occur, clean the tip with the Tip Cleaning Kit (PACE part number 6993-0200) by inserting the wire tool into the tip end.

Special Applications

If you require assistance in the use of this handpiece or with a special application, contact PACE Applications Support at:

Telephone: 1-888-535-7223 (toll-free) or (301) 490 - 9860

Fax: (301) 604 - 8782

Cleaning Solder Collection Chamber

As the Sodr-X-Tractor is used, solder and flux buildup will begin to impede the air flow and decrease system performance. Regular cleaning of the chamber will keep the Sodr-X-Tractor operating at peak performance. When cleaning the chamber, perform the following procedure using the illustration as a reference.

1. Remove any installed tip using the Tip Tool.
2. While holding the Sodr-X-Tractor tip up, remove the End Cap Assembly (refer to item ①) from the rear of the handpiece. This action is accomplished by pushing the End Cap Assembly toward the front of the handpiece and turning counterclockwise to disengage.

The glass chamber can be easily removed if it remains in the handpiece when the end cap assembly is removed. Insert a small flat blade screwdriver into the handpiece and gently push the front end of the glass chamber off the front seal.

NOTE

Do not attempt to remove the solder collection chamber (glass or silicone rubber chamber) from the Sodr-X-Tractor using pliers or any like tool. The use of such tools may cause damage to the chamber.

3. To remove the chamber from the End Cap Assembly (item ①), grasp the chamber by the end closest to the End Cap Assembly. On a heated extractor this end may be warm to the touch. DO NOT touch the other end as it initially may be too hot to touch. If dropped, a glass chamber is likely to break.

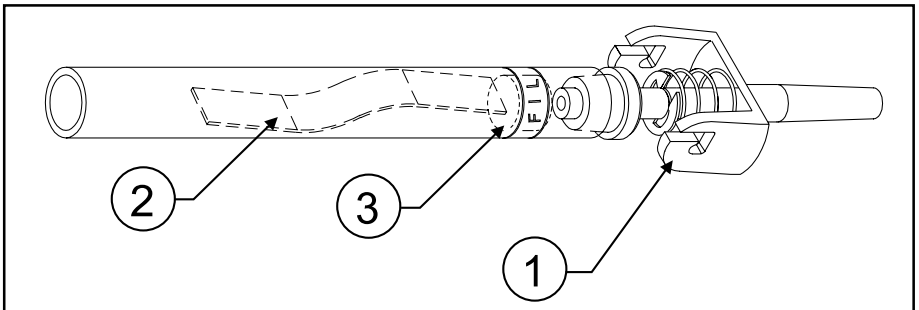

4. Clean and inspect the solder collection chamber in the following manner:
 - a) **Glass Chambers** - Push the S Baffle (item ②) and Filter (item ③) from the chamber. A bristle brush may be used for this purpose. Check for breaks or cracks in the glass and for broken or rough edges on the ends of the chamber. Replace if any damage is evident.

Clean the chamber and S Baffle with the large nylon bristle brush which has been wetted with an approved solvent. Run the brush through the chamber several times to remove solder and flux residues which have built-up. If desired, apply mineral oil to the brush and lightly coat the inside of the chamber and the S Baffle.

- b) **Silicone Rubber Chambers** - Remove the Filter (item ③) and S Baffle (item ②) from the chamber. Tap the side of the chamber against the side of a waste container to release residual solder. Check for any breaks or deformation of the chamber. After extended use, the ends of the chamber may deform and cause air leaks at the rubber seals (front and rear of handpiece). Replace if any damage is evident.
5. Assemble the solder collection chamber by installing the S Baffle (item ②) and a new Filter (item ③) into the chamber. The S Baffle should have enough tension to maintain a constant position within the chamber. Bending of the baffle slightly at the center will readjust the tension. Do not attempt to bend the baffle while installed in the chamber. The Filter must line up with the markings on a glass chamber (just clear of the End Cap Assembly in a silicone rubber chamber) and the rear of the S Baffle should be positioned just touching the Filter.
7. To ensure that the chamber will remain attached to the End Cap Assembly (item ①), seat the End Cap Assembly in the chamber and twist to secure in place.
8. Hold the Sodr-X-Tractor with the vacuum control switch in the upright position.
9. Insert the chamber into the Sodr-X-Tractor. Slide the chamber into the handpiece and onto the front heater seal.
10. Inspect for proper seating of the chamber on the front seal.
11. Attach the End Cap Assembly (item ①) to the Sodr-X-Tractor by pushing forward and turning clockwise to lock into place.
12. Check all air hose fittings. Actuate the vacuum and ensure that proper vacuum flow is present at the tip.

SX-70

Corrective Maintenance

Your SX-70 requires no special maintenance other than being kept clean. The heater bore and the heater assembly set screw which secures the tip must be kept free of oxidation and debris in order to maintain the proper tip-to-ground resistance.

Refer to the Handpiece Connector Plug pin out illustration and Table 1 for information on troubleshooting most handpiece problems. Disconnect the handpiece from the Power Source and perform the "Heater Assembly Checkout Procedures" with the handpiece (and heater) at room temperature. Use a meter to check resistance across the Handpiece Connector Plug pins as outlined in the "Checkout Procedure" column.

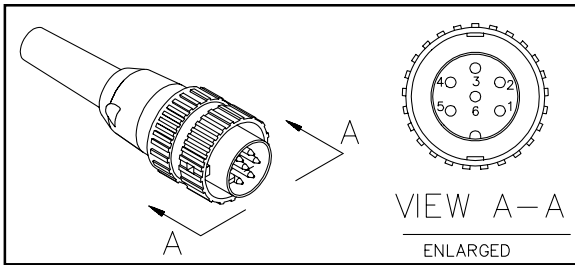

Handpiece Connector Plug

Sympto	Checkout	Procedure	Cause	Solution
No heat	Check resistance - Pin 2 to Pin 5. Resistance should be 8.2 to 9.5 ohms. If not - -	Open Heater	Replace Heater	
	Check resistance - Pin 3 to Pin 6. If circuit reads open - -	Open Sensor	Replace Heater	
Handpiec overheati	Check resistance - Pin 3 to Pin 6. Resistance should be 110 ohms. If circuit reads less than 105 ohms - -	Shorted Sensor	Replace Heater	
Fuse blows when unit is turned on	Check resistance - Pin 2 to Pin 5. Resistance should be 8.2 to 9.5 ohms. If not - -	Shorted Heater	Replace Heater Assembly	

Table 1. Heater Assembly Checkout Procedures

Spare Parts

Description	Part Number
Handle Assembly Kit	6993-0140
Heater Assembly	6010-0080-P1
Heater Set Screw	1348-0547-P10
Front (heater) Seal	1213-0033
Cord/Switch Assembly	4010-0098
Rear Seal Assembly	4010-0101
Glass Chamber	1265-0009-P1
Tubing, Silicone, Translucent, 54 Inches Long	1342-0001-13
Holder, Tube To Wire (pkg. of 6)	1321-0085-01
"S" Baffle	4010-0033
Filter (glass chamber)	1309-0018-P50
VisiFilter	1309-0028
VisiFilter Replacement Elements	1309-0027-P50
Tip Tool	1100-0206
Wire Brush, 3/16" Diameter	1127-0014-P5
Bristle Brush	1127-0002-P5
Sodr-X-Tractor Tip Cleaning Kit	6993-0200
PACE Screwdriver	1100-0230

Table 2. Spare Parts